

# NTD

NATIONAL TRACKED DUMPER HIRE LTD

## 13.2 TONNE 360° SLEW

## SPECIFICATION

All dimensions below were correct at time of print, E&OE.



### MODEL: PANTHER T14R

6 CYLINDER, DISPLACEMENT: 7.1 LITRES

253PS / 186KW @ 2200RPM / EU Stage 4 and 5

FUEL TANK CAPACITY: 300 LITRES (AD BLUE: 27 LITRES)

MACHINE WEIGHT: 16860KG

PAYLOAD: 13200KG

MAX TRAVEL SPEED: 13KPH

GROUND PRESSURE (UNLOADED): 5.1 PSI

GROUND PRESSURE (LOADED): 8.3 PSI

TRACK WIDTH: 750MM • SLEW RADIUS: 3200MM

DUMP BODY CAPACITY (STRUCK): 5.8M<sup>3</sup>

DUMP BODY CAPACITY (HEAPED): 6.6M<sup>3</sup>

This impressive sized tracked dumper offers high speed combined with an impressive payload for its class and sets high standards for productivity and mobility with its 13,200 kg capacity.

The rotating separation of this vehicle allows the operator to work in tight, sensitive areas where other vehicles do not have access. Together with a ground pressure of 8.3 psi and a strong pull ratio, these features allow this carrier crawler to be suitable for all major muck shifting, pipeline and most variations of projects, especially if the terrain is difficult, without damage to the environment. Tailgate option is available with the Panther T14R machine.

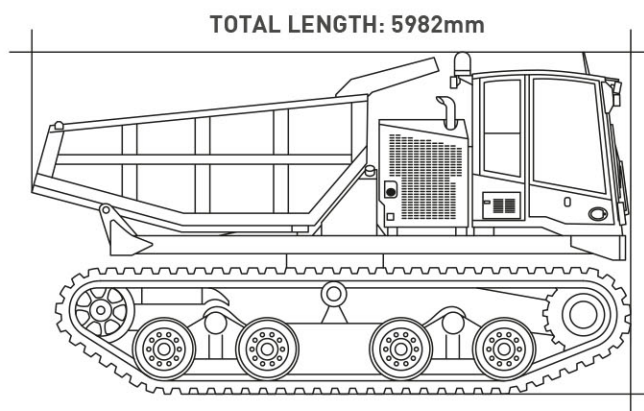
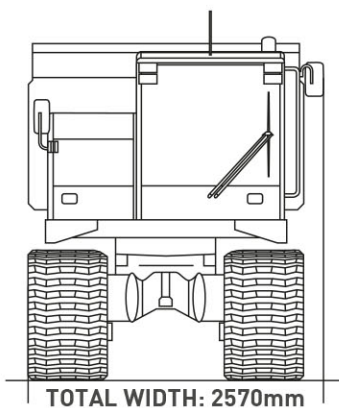

### FEATURE ICONS



HUMAN FORM RECOGNITION SYSTEM



ROPS OPERATORS CAB



BIODEGRADABLE HYDRAULIC OIL



HYDRAULIC ISOLATION SYSTEM



SEATBELT BEACON SYSTEM



REVERSING CAMERA



360° CAMERA



360° SLEWING

NTD National Tracked Dumper Hire Ltd, Weston Yard, Albury, Surrey GU5 9AF

0844 376 0051

hiredesk@ntdh.co.uk

www.ntdh.co.uk

